

**Features**

- +3.3V Input Voltage
- 20-A Output Current
- 5-bit Programmable: 1.075V to 1.85V (25mV Steps)
- VRM 9.0 Compatible
- High Efficiency (88%)
- Differential Remote Sense
- Over-Current Protection
- 27-Pin Space-Saving Package
- Solderable Copper Case
- Compatible with PT7744 20A “Current Booster”

**Description**

The PT7716 Excalibur™ power module is a 20-A integrated switching regulator (ISR) housed a 27-pin space-saving copper package. Operating from a 3.3V-input bus, the PT7716 produces a tightly regulated supply voltage that is programmable over the range, 1.075V to 1.85V. The output voltage is selected via a 5-bit code. The code adjusts the output voltage in steps of 25mV and is VRM 9.0 compatible.

This regulator is ideally suited for applications that employ microprocessor and DSP products that require core supply voltages as low as 1.075V.

The PT7716 includes a Shutdown control, Differential Remote Sense, and Short-Circuit Protection.

**Ordering Information**

PT7716□ = 1.075 to 1.85Volts  
PT7744□ = 20-A Booster \*

\* Consult the related application note for information on current booster operation.

**PT Series Suffix (PT1234 x)**

Case/Pin Configuration	Order Suffix	Package Code †
Vertical	<b>N</b>	(ENE)
Horizontal	<b>A</b>	(ENF)
SMD	<b>C</b>	(ENG)

† Previously known as package styles 1420 & 1430

(Reference the applicable package code drawing for the dimensions and PC board layout)

**Pin-Out Information**

Pin	Function	Pin	Function
1	VID0	15	GND
2	VID1	16	GND
3	VID2	17	GND
4	VID3	18	GND
5	STBY *	19	GND
6	VID4	20	V <sub>out</sub>
7	V <sub>in</sub>	21	V <sub>out</sub>
8	V <sub>in</sub>	22	V <sub>out</sub>
9	V <sub>in</sub>	23	V <sub>out</sub>
10	V <sub>in</sub>	24	V <sub>out</sub>
11	V <sub>in</sub>	25	V <sub>out</sub>
12	Rem Sense Gnd	26	Rem Sense V <sub>out</sub>
13	GND	27	Sync Out
14	GND		

\* For STBY pin: open =output enabled  
ground =output disabled.

**Standard Application**

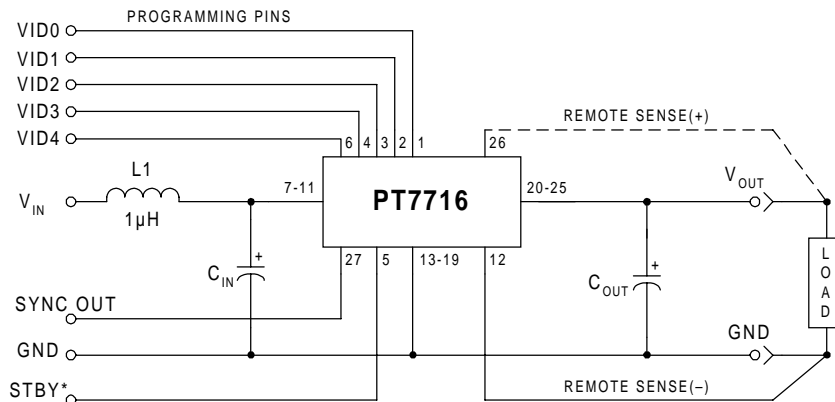

C<sub>in</sub> = Required 1500µF electrolytic  
C<sub>out</sub> = Required 330µF electrolytic  
L<sub>in</sub> = Optional 1µH input choke



**Performance Characteristics,  $V_{in} = 3.3V$**  (See Note A)

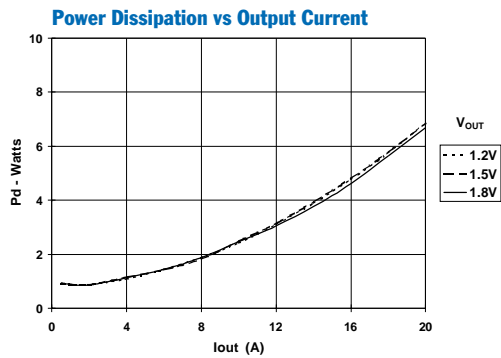
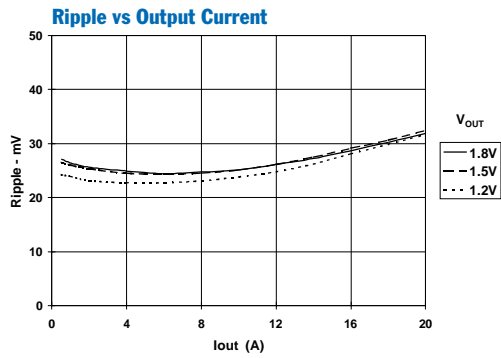
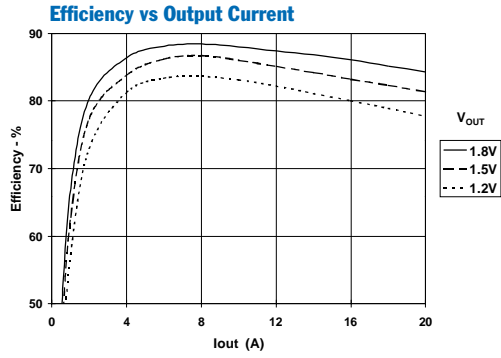

**Safe Operating Area Curves** (See Note B)

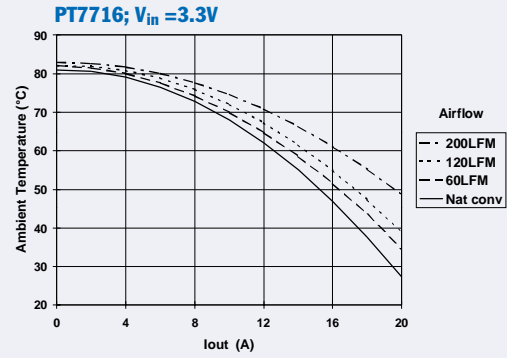

**Note A:** All characteristic data in the above graphs has been developed from actual products tested at 25°C. This data is considered typical for the ISR.  
**Note B:** SOA curves represent operating conditions at which internal components are at or below manufacturer's maximum rated operating temperatures.

## Capacitor Recommendations for the PT7710 Series of Regulators and Current Boosters

### Input Capacitors

The recommended input capacitance is determined by the 1.4 ampere minimum ripple current rating and 1500 $\mu$ F minimum capacitance. Capacitors listed below must be rated for a minimum of twice (2 $\times$ ) the input voltage with +5V operation. Ripple current and  $\leq 100\text{m}\Omega$  Equivalent Series Resistance (ESR) values are the major considerations along with temperature when selecting the proper capacitor.

### Output Capacitors

The minimum required output capacitance is 330 $\mu$ F with a maximum ESR less than or equal to 100m $\Omega$ . Failure to observe this requirement may lead to regulator instability or oscillation. Electrolytic capacitors have poor ripple performance at frequencies greater than 400kHz, but excellent low frequency transient response. Above the ripple frequency ceramic decoupling capacitors are necessary to improve the transient response and reduce any microprocessor high frequency noise components apparent during higher current excursions. Preferred low ESR type capacitor part numbers are identified in the Table 1-1 below.

### Tantalum Characteristics

Tantalum capacitors with a minimum 10-V rating are recommended on the output bus, but only the AVX TPS Series, Sprague 594/595 Series, or Kemet T495/T510 Series. These AVX, Sprague, and Kemet capacitors are specified over other types due to their higher surge current, excellent power dissipation and ripple current ratings. As a caution, the TAJ Series by AVX is not recommended. This series exhibits considerably higher ESR, reduced power dissipation and lower ripple current capability. The TAJ series is also less reliable compared to the TPS series when determining power dissipation capability.

### Capacitor Table

Table 1-1 identifies the characteristics of capacitors from a number of vendors with acceptable ESR and ripple current (rms) ratings. The suggested minimum quantities per regulator for both the input and output buses are identified.

*This is not an extensive capacitor list. Capacitors from other vendors are available with comparable specifications. The RMS ripple current rating and ESR (Equivalent Series Resistance at 100kHz) are the critical parameters necessary to insure both optimum regulator performance and long capacitor life.*

**Table 1-1 Capacitors Characteristic Data**

Capacitor Vendor/ Series	Capacitor Characteristics					Quantity		Vendor Number
	Working Voltage	Value( $\mu$ F)	(ESR) Equivalent Series Resistance	105°C Maximum Ripple Current(Irms)	Physical Size(mm)	Input Bus	Output Bus	
Panasonic FC (SMT)	16V	2200	0.038 $\Omega$	2000mA	18x16.5	1	1	EEVFC1C222N EEVFC1V331LQ
	35V	330	0.065 $\Omega$	1205mA	12.5x16.5			
FC (Radial)	10V	560	0.090 $\Omega$	755mA	10x12.5	1	1	EEUFC1A561 EEUFC1C182S
	16V	1800	0.032 $\Omega$	2000mA	18x15			
United Chemi -Con LFZ Series	25V	330	0.090 $\Omega$	760mA	10x12.5	1	1	LXZ25VB331M10X12LL LXZ16VB222M12X20LL LXZ16VB471M10X12LL
	16V	1500	0.038 $\Omega$	1660mA	12.5x20			
	16V	470	0.090 $\Omega$	760mA	10x12.5			
Nichicon PL Series PM Series	10V	680	0.090 $\Omega$	770mA	10x15	1	1	UPL1A681MHH6 UPL1A182MHH6 UPL1E331MPH6
	10V	1800	0.044 $\Omega$	1420mA	16x15			
	25V	330	0.095 $\Omega$	750mA	10x15			
Oscon SS (Radial) SVP (SMT)	10V	330	0.025 $\Omega$ $\pm$ 4 =0.006 $\Omega$	>9800mA	10x10.5	4	N/R (Note)	10SS330M 10SVP330M
	10V	330	0.02 $\Omega$ $\pm$ 4 =0.005 $\Omega$	>9800mA	9x8.3			
AVX Tantalum TPS- Series	10V	330	0.1 $\Omega$ $\pm$ 5 =0.02 $\Omega$	3500mA	7.3Lx	5	1	TPSV337M010R0100 TPSV337M010R0060
	10V	330	0.06 $\Omega$	1826mA	4.3Wx 4.1H			
Sprague Tantalum 595D/594D	10V	330	0.045 $\Omega$ $\pm$ 4 =0.011 $\Omega$	>4500mA	7.3L x	5	1	594D337X0010R2T 595D687X0010R2T (Surface Mount)
	10V	680	0.09 $\Omega$	>1660mA	5.7W x 4.0H			
Kemet Tantalum T510/T495 Series	10V	330	0.035 $\Omega$	2000mA	4.3Wx7.3L x4.0H	5	1	510X337M010AS T495X227M010AS (Surface Mount)
	10V	220	0.07 $\Omega$ $\pm$ 2 =0.035 $\Omega$	>2000mA				
Sanyo Poscap TPB	10V	220	0.04 $\Omega$	3000mA	7.2L x 4.3W x 3.1H	6	2	10TPB220M (Surface Mount)

**Note:** (N/R) is not recommended for this application, due to extremely low Equivalent Series Resistance (ESR)

## Increasing the Output of the PT7710 Family of ISRs with a 20-A Compatible Current Booster

The output of PT7710 family of regulators (PT7711–PT7716) can produce an additional 20-A output using a compatible current booster module. Two booster modules are available. They are the PT7744 and PT7745, which are compatible with regulators that operate off 3.3-V or 5-V input buses respectively. Refer to Table 2-1 for regulator/booster compatibility.

The booster modules are controlled directly by the regulator and effectively add a parallel output stage. They operate synchronously, to provide a low-noise solution. Up to two booster modules can be connected to a PT771x regulator. Each booster added increases the regulator’s output current by 20A, for up to 60A of output current.

Current boosters are not stand-alone products, and can only operate with a regulator. They are housed in the same package as the regulator, and share the same mechanical outline. Except for an increase in output current, the overall performance of a regulator/booster combination is identical to that of a stand-alone regulator. For more details refer to the applicable regulator specifications.

**Table 2-1; Booster Compatibility**

Regulator	P7744 Booster (3.3V Input Bus)	PT7745 Booster (5V Input Bus)
PT7711	•	•
PT7712	•	
PT7713	•	
PT7714	•	
PT7715		•
PT7716	•	

**Notes:**

1. Each booster requires the same amount of input and output capacitance as recommended for a stand-alone regulator. Consult the individual data sheet of the applicable regulator, and the related application note regarding capacitor selection for this product family.
2. The 1- $\mu$ H filter choke located at the input of each regulator and booster module ( $L_{in}$ ) is optional for most applications. If specified, each inductor must be sized to handle 20ADC at full output load.
3. The pin-out of the current booster modules include a number pins identified, “No Connect” (see Table 2-2). These pins are not connected internally to the module but must be soldered to a pad to preserve the unit’s mechanical integrity.
4. A similar PCB footprint and trace layout between the regulator and each booster will facilitate current sharing between all modules.

**Table 2-2; Booster Pin-Out Information**

Pin	Function	Pin	Function	Pin	Function
1	No Connect	10	$V_{in}$	19	GND
2	No Connect	11	$V_{in}$	20	$V_{out}$
3	No Connect	12	No Connect	21	$V_{out}$
4	No Connect	13	GND	22	$V_{out}$
5	No Connect	14	GND	23	$V_{out}$
6	No Connect	15	GND	24	$V_{out}$
7	$V_{in}$	16	GND	25	$V_{out}$
8	$V_{in}$	17	GND	26	No Connect
9	$V_{in}$	18	GND	27	Sync In

**Figure 1-1; Current Booster Application Schematic**

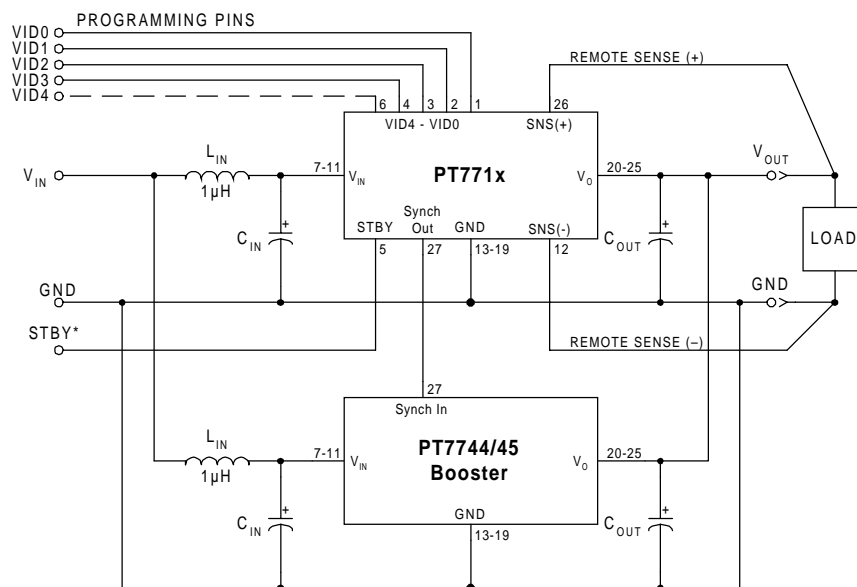

### Using the Standby Function on the PT7710 Excalibur™ Series of 20-A ISRs

For applications requiring On/Off control of the output voltage, the PT7710 family of Excalibur ISRs incorporate a standby function. This feature may be used for power-up/shutdown sequencing, or to change the output voltage while input power is applied. *See related notes:* “Pin-Coded Output Voltage Adjustment of the PT7710 Excalibur™ Series of 20-A ISRs.”

The standby function is provided by the *STBY*\* control, pin 5. If pin 5 is left open-circuit the regulator operates normally, providing a regulated output whenever a valid supply voltage is applied to  $V_{in}$  (pins 7-11) with respect to GND (pins 13-19). Connecting pin 5 to ground<sup>1</sup> will set the regulator output to zero volts<sup>2</sup>. This places the regulator in standby mode, and reduces the input current to typically 30mA (60mA max). If a ground signal is applied to pin 5 prior to power-up, the regulator output will be held at zero volts during the period that input power is applied.

The standby input must be controlled with an open-collector (or open-drain) discrete transistor (See Figure 1). Table 3-1 gives the input requirements.

**Table 3-1 Standby Control Input Requirements<sup>(1,2)</sup>**

Parameter	Min	Typ	Max
Enable	2V		Open Cct. 1
Disable	-0.2V		0.8V
$I_{stby} (low)$			0.5mA
$V_{stby} (o/c)$		$V_{in}$	

#### Notes:

- The Standby input on the PT7710 regulator family must be controlled using an open-collector (or open-drain) discrete transistor. *Do Not* use a pull-up resistor. The control input has an open-circuit voltage equal to  $V_{in}$ . To set the regulator output to zero, the control pin must be “pulled” to less than 0.8Vdc with a 0.5mA sink to ground.
- When placed in the standby mode, the regulator output discharges the output capacitance with a low impedance to ground.
- The turn-off time of  $Q_1$ , or rise time of the standby input is not critical with the PT7710 family. Turning  $Q_1$  off slowly, over periods up to 100ms, will not affect regulator operation. However, a slow turn-off time will increase both the initial delay and rise-time of the output voltage.

**Figure 3-1**

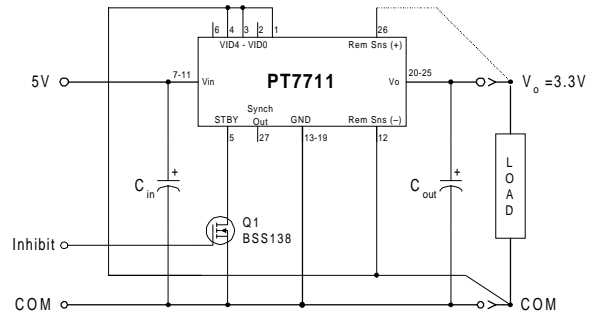

**Turn-On Time:** Turning  $Q_1$  in Figure 3-1 off, removes the low-voltage signal at pin 5 and enables the output. After a delay of approximately 10ms, the output voltage of a PT771x regulator rises to full regulation within 30ms<sup>3</sup>. Figure 3-2 shows the typical output voltage waveform of a PT7711 following the turn-off of  $Q_1$  at time  $t=0$  secs. The output voltage in Figure 3-1 is set to 3.3V by connecting VID0 (pin 1), VID2 (pin 3), and VID3 (pin 4) to the ‘Rem Sense Gnd’ (pin 12)\*. The waveform was measured with a +5V input source voltage, and 10-A resistive load.

**Figure 3-2**

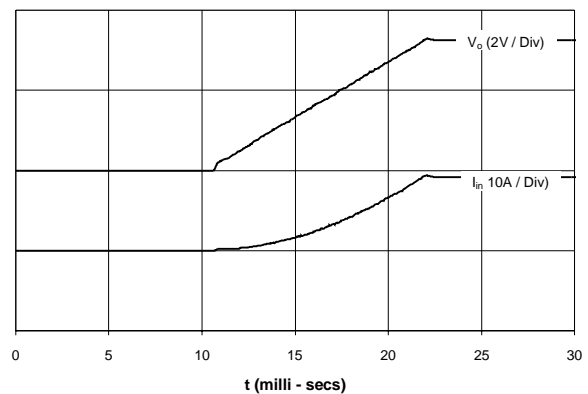

\* Consult the data sheet for details on other VID codes.

## Pin-Coded Output Voltage Adjustment of the PT7710 Excalibur™ Series of 20-A ISRs

The PT7710 Excalibur™ family of converters incorporate a pin-coded control to adjust the output voltage. This feature uses the control pins VID0–VID4 (pins 1–6). When the control pins are left open-circuit, the ISR output regulates at its default output voltage. Each control pin is internally connected to a precision resistor, which when grounded applies a weighted change to the output voltage. By selectively grounding VID0–VID4, the output voltage of these ISRs can be programmed in incremental steps over the specified output voltage range. The program codes and output voltage range offered by these ISRs are compatible with the Voltage ID specifications defined by Intel Corporation for VRMs (voltage regulator modules). The codes are used by both the Pentium® and Athlon® microprocessors. Refer to Figure 4-1 for the connection schematic, and the respective device Data Sheet for the programming code information.

### Notes:

- The programming convention is as follows:-  
 Logic 0: Connect to pin 12 (Remote Sense Ground).  
 Logic 1: Open circuit/open drain (See notes 2, & 4)
- Do not connect pull-up resistors to the voltage programming pins.
- Use pin 12 (Remote Sense Ground) as the logic “0” reference. While the regular ground (pins 13-19) can also be used for programming, doing so will degrade the load regulation of the product. If the remote sense ground is not used, pin 12 must be connected to pin 13 for optimum output voltage accuracy.

- If active devices are used to ground the voltage control pins, low-level open drain MOSFET devices should be used over bipolar transistors. The inherent  $V_{ce(sat)}$  in bipolar devices introduces errors in the device’s internal divider network. Discrete transistors such as the BSS138, 2N7002, or IRLML2402 are examples of appropriate devices.

### Active Voltage Programming:

Special precautions should be taken when making changes to the output voltage program code while the unit is powered. This activity can induce current transients through the device as a result of the electrolytic output capacitors being either charged or discharged to the new output voltage set-point. The transient current can be minimized by making only incremental changes to the binary code, i.e. one LSB at a time. A minimum of 100µs settling time between each program state is also recommended. Making non-incremental changes to VID3 or VID4 is discouraged.

When active devices are used to program the output voltage, their state should be asserted prior to the input power being applied. An alternative is to pull pin 5 (STBY) control to GND during the application of input voltage, then assert the required program code and release pin 5. The module will then initiate a soft-start power-up to the desired program voltage. For more information on the use of the Standby function, consult the related application note, “Using the Standby Function on the PT7710 Excalibur™ Series of 20-A ISRs.”

Figure 4-1

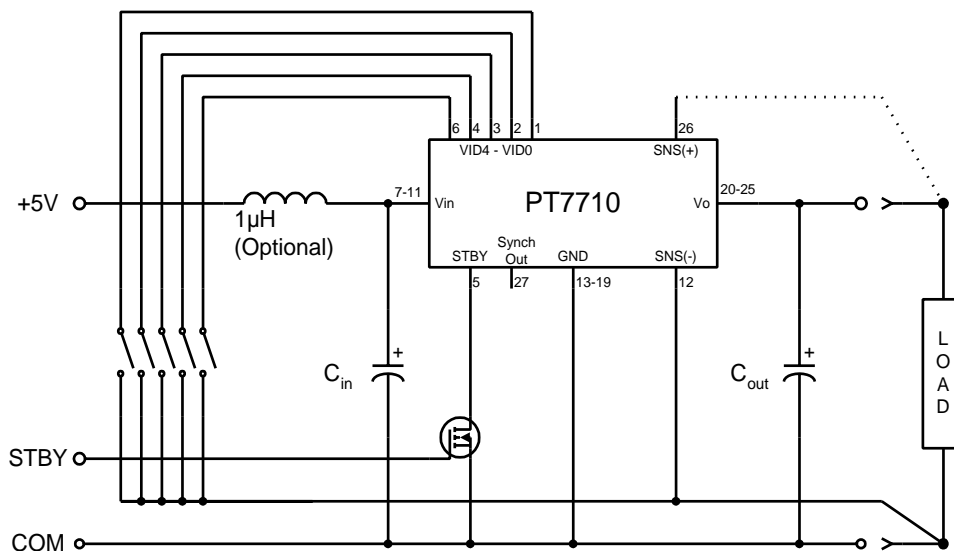

## IMPORTANT NOTICE

Texas Instruments Incorporated and its subsidiaries (TI) reserve the right to make corrections, modifications, enhancements, improvements, and other changes to its products and services at any time and to discontinue any product or service without notice. Customers should obtain the latest relevant information before placing orders and should verify that such information is current and complete. All products are sold subject to TI's terms and conditions of sale supplied at the time of order acknowledgment.

TI warrants performance of its hardware products to the specifications applicable at the time of sale in accordance with TI's standard warranty. Testing and other quality control techniques are used to the extent TI deems necessary to support this warranty. Except where mandated by government requirements, testing of all parameters of each product is not necessarily performed.

TI assumes no liability for applications assistance or customer product design. Customers are responsible for their products and applications using TI components. To minimize the risks associated with customer products and applications, customers should provide adequate design and operating safeguards.

TI does not warrant or represent that any license, either express or implied, is granted under any TI patent right, copyright, mask work right, or other TI intellectual property right relating to any combination, machine, or process in which TI products or services are used. Information published by TI regarding third-party products or services does not constitute a license from TI to use such products or services or a warranty or endorsement thereof. Use of such information may require a license from a third party under the patents or other intellectual property of the third party, or a license from TI under the patents or other intellectual property of TI.

Reproduction of information in TI data books or data sheets is permissible only if reproduction is without alteration and is accompanied by all associated warranties, conditions, limitations, and notices. Reproduction of this information with alteration is an unfair and deceptive business practice. TI is not responsible or liable for such altered documentation.

Resale of TI products or services with statements different from or beyond the parameters stated by TI for that product or service voids all express and any implied warranties for the associated TI product or service and is an unfair and deceptive business practice. TI is not responsible or liable for any such statements.

### Mailing Address:

Texas Instruments  
Post Office Box 655303  
Dallas, Texas 75265